

6. Pump Sealing

This section describes the principle of pump sealing and illustrates the different sealing arrangements used on Alfa Laval pump ranges. A general seal selection guide is included, together with various operating parameters.

This section covers the shaft sealing devices used on Alfa Laval Centrifugal, Liquid Ring and Rotary Lobe Pumps. In addition to shaft seals, other proprietary seals not detailed in this section, such as o-rings and lip seals can be found on the pumphead and gearcase.

“A Pump is only as good as it’s shaft seal”

A successful pump application largely depends upon the selection and application of suitable fluid sealing devices. Just as we know that there is no single pump that can embrace the diverse range of fluids and applications whilst meeting individual market requirements and legislations, the same can be said of fluid sealing devices. This is clearly illustrated by the large range of shaft seal arrangements, both mechanical and packed gland, that are available to the pump manufacturer.

Shaft sealing devices used in Alfa Laval Centrifugal, Liquid Ring and Rotary Lobe pumps include:

- Mechanical Seals (see 6.2).
 - Single externally mounted.
 - Single internally mounted.
 - Single externally mounted for external flush.
 - Single internally mounted for product recirculationor
 - Double ‘back to back’ with the inboard seal externally mounted for flush.

- Packed Glands (see 6.3).
 - Both with and without lantern rings for flush.

Centrifugal and Liquid Ring pumps only have one shaft seal whereas Rotary Lobe pumps employ a minimum of two shaft seals (one per shaft). Generally all shaft seals are under pressure with the pressure gradient across the seal being from pumped fluid to atmosphere. The exceptions will be single internally mounted or double seals where the product recirculation (single internally mounted only) or flush pressure is greater than the pump pressure, resulting in the pressure gradient being reversed.

Mechanical seals meet the majority of application demands and of these, single and single flushed seals are most frequently specified. The application of double mechanical seals is increasing to meet both process demands for higher sanitary standards and legislation requirements, particularly those related to emissions.

The majority of proprietary mechanical seals available from seal manufacturers have been designed for single shaft pump concepts, such as Centrifugal and Liquid Ring pumps. These pump types do not impose any radial or axial constraints on seal design. However on Rotary Lobe type pumps the need to minimise the shaft extension beyond the front bearing places significant axial constraints. If this were extended, the shaft diameter would increase introducing a radial constraint - because shafts on a rotary lobe pump are in the same plane, the maximum diameter of the seal must be less than the shaft centres. Most designs therefore can only accommodate 'bespoke' or 'customised' seal design. This is not done to take any commercial advantage but it is as a consequence of the rotary lobe pump design concept.

There is often more than one solution and sometimes no ideal solution, therefore a compromise may have to be considered.

Selection of shaft seals is influenced by many variables:

- Shaft diameter and speed
- Fluid to be pumped
 - Temperature
 - effect on materials?
 - can interface film be maintained?
 - Viscosity
 - drag on seal faces?
 - clogging of seal restricting movement?
 - can interface film be established and maintained?
 - stiction at seal faces?
 - Fluid behaviour
 - does product shear, thin, thicken or 'work' - balling/carbonise?
 - can interface film be established and maintained?
 - Solids
 - size?
 - abrasiveness?
 - density?
 - clogging of seal restricting movement?
 - can interface film be established and maintained?
 - Thermal stability
 - Air reacting
 - what, if any change?
- Pressure
 - within seal limits?
 - fluctuations?
 - peaks/spikes?
 - cavitation?
- Services
 - flush?
 - pressure?
 - temperature?
 - continuity?
- Health and Safety
 - toxic?
 - flammable?
 - explosive?
 - corrosive?
 - irritant?
 - carcinogenic?

6.1 Mechanical Seals - General

Mechanical seals are designed for minimal leakage and represent the majority of Centrifugal, Liquid Ring and Rotary Lobe pump sealing arrangements.

Mechanical seal selection must consider:

- The materials of seal construction, particularly the sealing faces and elastomers.
- The mounting attitude to provide the most favourable environment for the seal.
- The geometry within which it is to be mounted.

A mechanical seal typically comprises:

- A primary seal, comprising stationary and rotary seal rings.
- Two secondary seals, one for each of the stationary and rotary seal rings.
- A method of preventing the stationary seal ring from rotating.
- A method of keeping the stationary and rotary seal rings together when they are not hydraulically loaded i.e. when pump is stopped.
- A method of fixing and maintaining the working length.

The Primary Seal

Comprises two flat faces, one rotating and one stationary, which support a fluid film, thus minimising heat generation and subsequent mechanical damage.

Commonly used material combinations are:

Carbon	-	Stainless Steel
Carbon	-	Silicon Carbide
Carbon	-	Tungsten Carbide
Silicon Carbide	-	Silicon Carbide
Tungsten Carbide	-	Tungsten Carbide

The Secondary Seal

This is required to provide a seal between the primary seal rings and the components with which they interface. Also it can provide a cushion mounting for the seat ring to reduce any effects of mechanical stress i.e. shock loads.

Types of secondary seal are:

- O-rings • Cups • Gaskets • Wedges

For Alfa Laval pump ranges the o-ring is the most common type of secondary seal used. Its simple and versatile concept is enhanced with the following comprehensive material options:

- NBR • EPDM • FPM • PTFE • MVQ • FEP • Kalrez® • Chemraz®

These are fully described in section 5.3.

Mechanical Seal Face/'O' Ring Material Availability

Pump Type	Pump Range	Rotary Seal Face				Stationary Seal Face				Seal 'O'Ring					
		Carbon	Stainless Steel	Silicon Carbide	Tungsten Carbide	Carbon	Stainless Steel	Silicon Carbide	Tungsten Carbide	NBR	EPDM	FPM	PTFE	MVQ	FEP
Centrifugal/ Liquid ring	LKH	✓		✓				✓		✓	✓	✓			✓
	LKH-Multistage	✓		✓				✓		✓	✓	✓			✓
	LKHP-High Pressure			✓				✓		✓	✓	✓			✓
	LKHSP	✓						✓		✓	✓	✓			✓
	LKHI	✓		✓				✓		✓	✓	✓			✓
	LKH-Ultra Pure MR	✓	✓	✓		✓	✓	✓		✓	✓	✓			✓
Rotary Lobe	SRU		✓	✓	✓	✓		✓	✓	✓	✓	✓			
	SX (see note)	✓		✓				✓	✓		✓	✓		✓	

Note: SX1 pump has tungsten carbide seal faces, not silicon carbide seal faces.

Table 6.1a

Stationary Seal Ring Anti-Rotation

Ideally the selected device listed below will also allow for axial resilience.

- Flats • Pins • Elastomer resilience • Press fit • Clamps

Rotary Seal Ring Drive

Ideally the selected device listed below will allow for a degree of axial movement.

- Spring • Bellows • Physical positioning • Elastomer resilience

One of the main causes of seal failure is for the seal working length not being correctly maintained.

Fig. 6.1a Typical single mechanical seal used in rotary lobe pumps

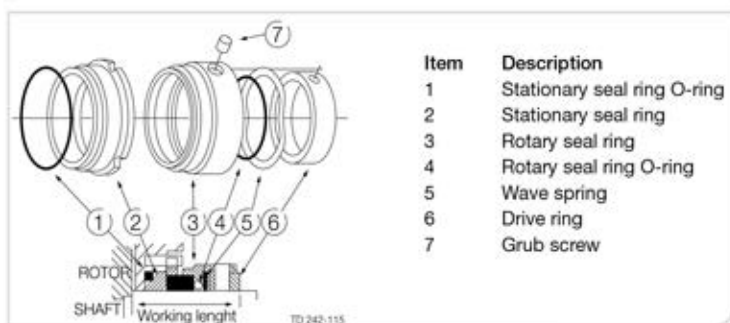

Fig. 6.1b Typical single mechanical seal used in centrifugal pumps

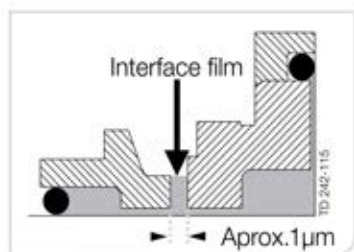
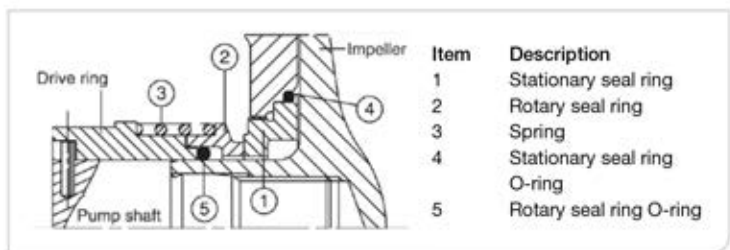
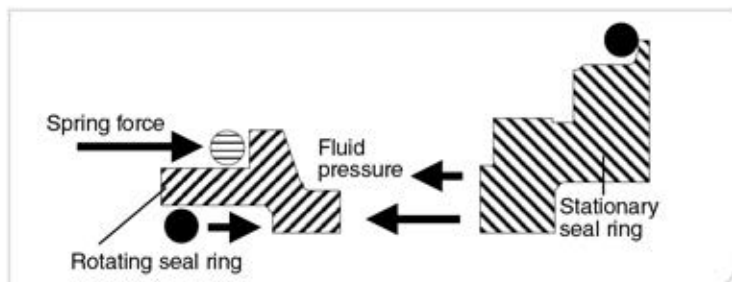

Fig. 6.1c Principle of mechanical seal operation

Principle of Mechanical Seal Operation

The function of the assembly is a combination of the extreme primary seal face flatness and applied spring force. Once the pump is operational, hydraulic fluid forces combine with seal design features i.e. balance, which push the seal faces together. This reduces the fluid interface thickness to a minimum whilst increasing pressure drop, therefore minimising pumped fluid leakage.

Fig. 6.1d Principle of mechanical seal operation



The gap between the seal ring surfaces is enlarged to clarify the principle of mechanical sealing.

Mechanical Seal Mounting

Most mechanical seals can be mounted externally or internally.

External Mechanical Seals

The majority of mechanical seals used on Alfa Laval pump ranges are mounted externally, meaning that all the rotating parts of the mechanical seal (i.e. part of the rotary seal ring, spring, drive ring etc) are not in contact with the fluid to be pumped. The externally mounted mechanical seal is considered easy to clean, as only the inside of the stationary and rotary seal rings and their associated o-rings are in contact with the fluid being pumped. The R00 type mechanical seals used on the SX rotary lobe pump range, described in 6.2, are an exception to this, as it is the outside and not the inside of the seal components that is in contact with the fluid being pumped. Externally mounted seals have a lower pressure rating than the equivalent seal mounted internally.

Fig. 6.1e Typical external shaft seal

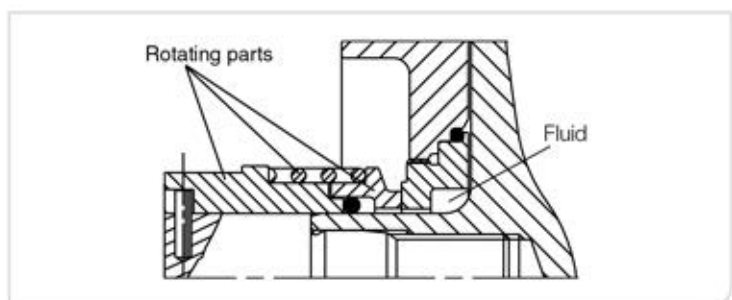

Internal Mechanical Seals

Some mechanical seals are mounted internally, meaning that most of the rotating parts are in contact with the fluid being pumped. The internal mechanical seal is designed with sufficient clearance around the rotating parts so that it can be cleaned as efficiently as possible and can withstand relatively high fluid pressures.

Fig. 6.1f Typical internal shaft seal

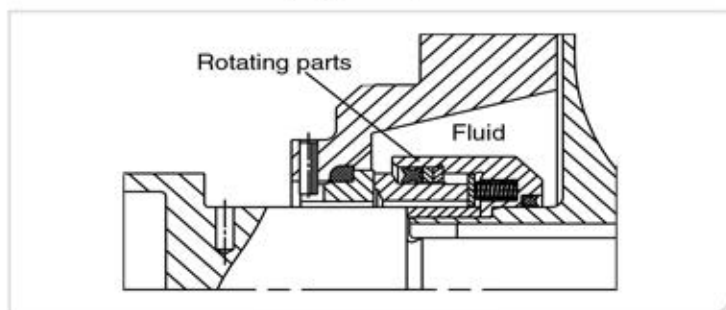

For the Alfa Laval pump ranges, both the externally and internally mounted types of mechanical seal are available as single and single flushed versions. The externally mounted mechanical seal on Alfa Laval pump ranges is also available as a double flushed mechanical seal for some pump models. The typical single, single flushed and double flushed mechanical seal arrangements are described as follows:

Single Mechanical Seal

This is the simplest shaft seal version, which has already been described previously in this section. This seal arrangement is generally used for fluids that do not solidify or crystallise in contact with the atmosphere and other non-hazardous duties. For satisfactory operation it is imperative the seal is not subjected to pressures exceeding the maximum rated pressure of the pump. Also the pump must not be allowed to run 'dry', thus avoiding damage to the seal faces, which may cause excessive seal leakage.

Typical applications are listed below, but full product/fluid and performance data must be referred to the seal supplier for verification.

- Alcohol • Animal Fat • Aviation Fuel • Beer • Dairy Creams
- Fish Oil • Fruit Juice • Liquid Egg • Milk • Shampoo
- Solvents • Vegetable Oil • Water • Yoghurt

Single Flushed Mechanical Seal

The definition of 'flush' is to provide a liquid barrier or support to the selected seal arrangement. This seal arrangement is generally used for any of the following conditions:

- where the fluid being pumped can coagulate, solidify or crystallise when in contact with the atmosphere.
- when cooling of the seals is necessary dependent upon the fluid pumping temperature.

This seal arrangement used on externally mounted seals requires the supply of liquid to the atmospheric side of the mechanical seal to flush the seal area. The characteristics of the fluid being pumped and the duty conditions will normally determine if a flush is necessary. When selecting a flushing liquid you must ensure that it is chemically compatible with the relevant materials of pump/seal construction and fully compatible with the fluid being pumped. Consideration should be given to any temperature limitations that may apply to the flushing liquid to ensure that hazards are not created (i.e. explosion, fire, etc). The flushing liquid is allowed to enter the seal housing at low pressure i.e. 0.5 bar max (7 psi max) to act as a barrier.

This most basic flush system, sometimes referred to as quench, provides liquid to the atmosphere side of the mechanical seal thereby flushing away any product leakage. For the majority of pump models the flushed seal comprises the same stationary and rotating parts as the single seal, with the addition of a seal housing having a flushing connection and/or flushing tubes and a lip seal.

Fig. 6.1g Typical externally mounted single flushed mechanical seal used in rotary lobe pumps

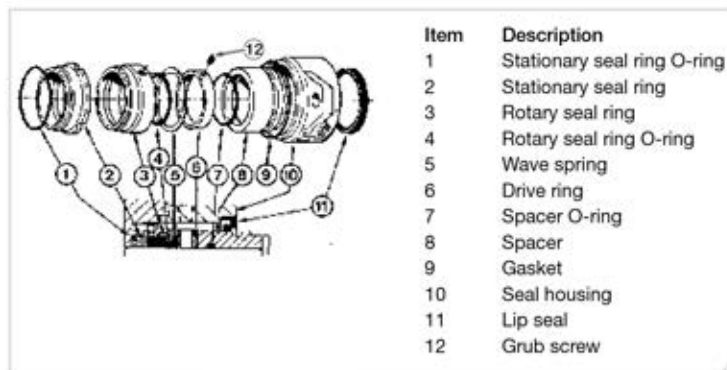
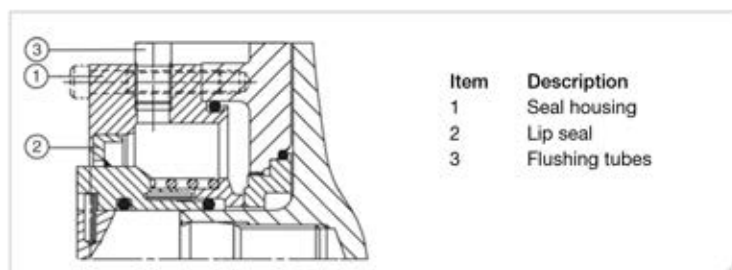

Fig. 6.1h Typical externally mounted single flushed mechanical seal used in centrifugal pumps



Typical applications are listed below, but full product/fluid and performance data must be referred to the seal supplier for verification.

- Adhesive • Caramel • Detergent • Fruit Juice Concentrate • Gelatine • Jam • Latex • Paint • Sugar Syrup • Toothpaste • Yeast

Double Flushed Mechanical Seal

This seal arrangement is generally used with hostile media conditions i.e. high viscosity, fluid is hazardous or toxic. The double flushed seal used on Alfa Laval pump ranges is basically two single mechanical seals mounted 'back to back'. This seal generally comprises the same stationary and rotating parts as the single seal for the majority of pump models, with the addition of a seal housing having a flushing connection and/or flushing tubes (dependent upon pump type). A compatible flushing liquid is pressurised into the seal housing at a pressure of 1 bar (14 psi) minimum above the discharge pressure of the pump. This results in the interface film being the flushing liquid and not the pumped liquid. Special attention is required in selecting seal faces and elastomers.

The arrangement in contact with the pumped fluid is referred to as the 'inboard seal', and the seal employed for the flushing liquid is referred to as the 'outboard seal'. For Alfa Laval Centrifugal pumps the design of the outboard seal differs to the inboard seal.

Fig. 6.1i Typical double flushed mechanical seal used in rotary lobe pumps

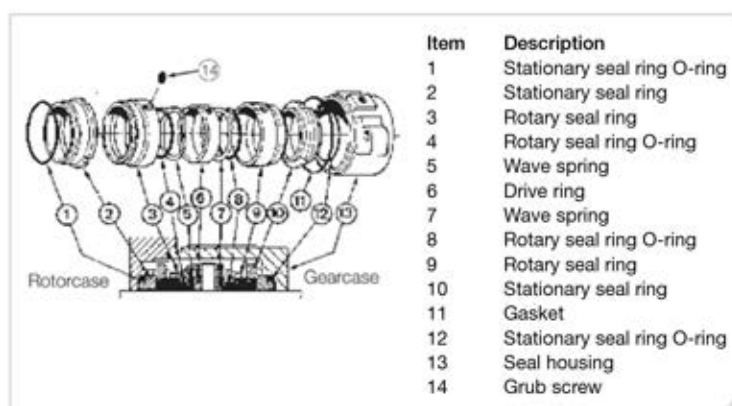
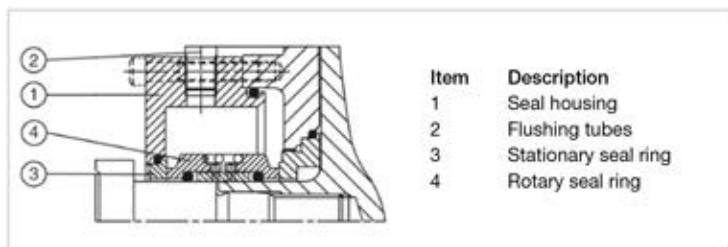

Fig. 6.1j Typical double flushed mechanical seal used in centrifugal pumps



Typical applications are listed below, but full product/fluid and performance data must be referred to the seal supplier for verification.

- Abrasive Slurries • Chocolate • Glucose • Hazardous Chemicals
- PVC Paste • Photographic Emulsion • Resin

General Seal Face Operating Parameters

Tables below show general parameters regarding viscosity and temperature, which should be noted when selecting a mechanical seal.

Table 6.1b

Viscosity	Seal Face Combination
up to 4999 cP	Solid Carbon v Stainless Steel Solid Carbon v Silicon Carbide Solid Carbon v Tungsten Carbide
up to 24999 cP	Inserted Carbon v Stainless Steel Inserted Carbon v Silicon Carbide Inserted Carbon v Tungsten Carbide
up to 149999 cP	Silicon Carbide v Silicon Carbide Tungsten Carbide v Tungsten Carbide
above 150000 cP	Consider Double Seals

Table 6.1c

Temperature	Seal Face Combination
up to 150°C (302°F)	Inserted Carbon v Stainless Steel Inserted Carbon v Silicon Carbide Inserted Carbon v Tungsten Carbide Silicon Carbide v Silicon Carbide Tungsten Carbide v Tungsten Carbide
up to 200°C (392°F)	Solid Carbon v Stainless Steel Inserted Carbon v Silicon Carbide Inserted Carbon v Tungsten Carbide

Flushing Pipework Layout

The suggested arrangement below is for single mechanical seals only. If the pump is fitted with double mechanical seals or packed glands the pressure gauges and control valves should be fitted on the outlet side of the system. The choice of flushing liquid is dependent upon compatibility with the pumping media and overall duty conditions i.e. pressure and temperature. Usually water is used for cooling and any water soluble products.

Fig. 6.1k Typical flushing pipework layout for a rotary lobe pump

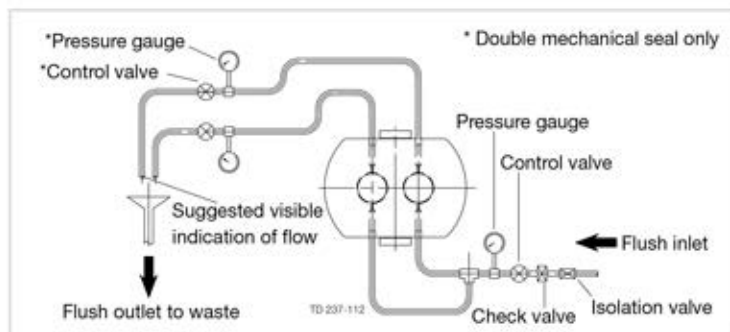
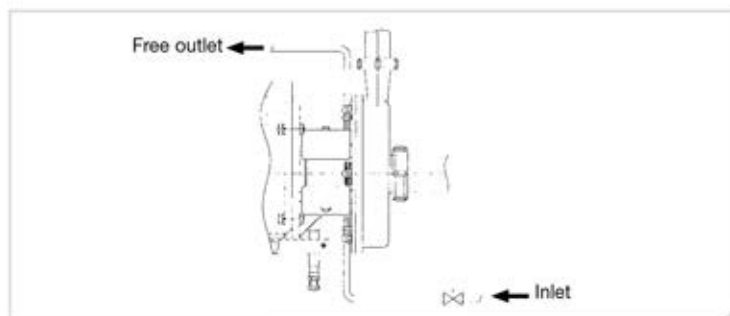

Fig. 6.1l Typical flushing pipework layout for a centrifugal pump



Mechanical Seal Selection Process

The illustration below describes the mechanical seal selection process with relevant questions to be answered.

Fig. 6.1m Seal selection process

This should be used for guidance purposes only, as actual seal selections should be verified by the seal suppliers.

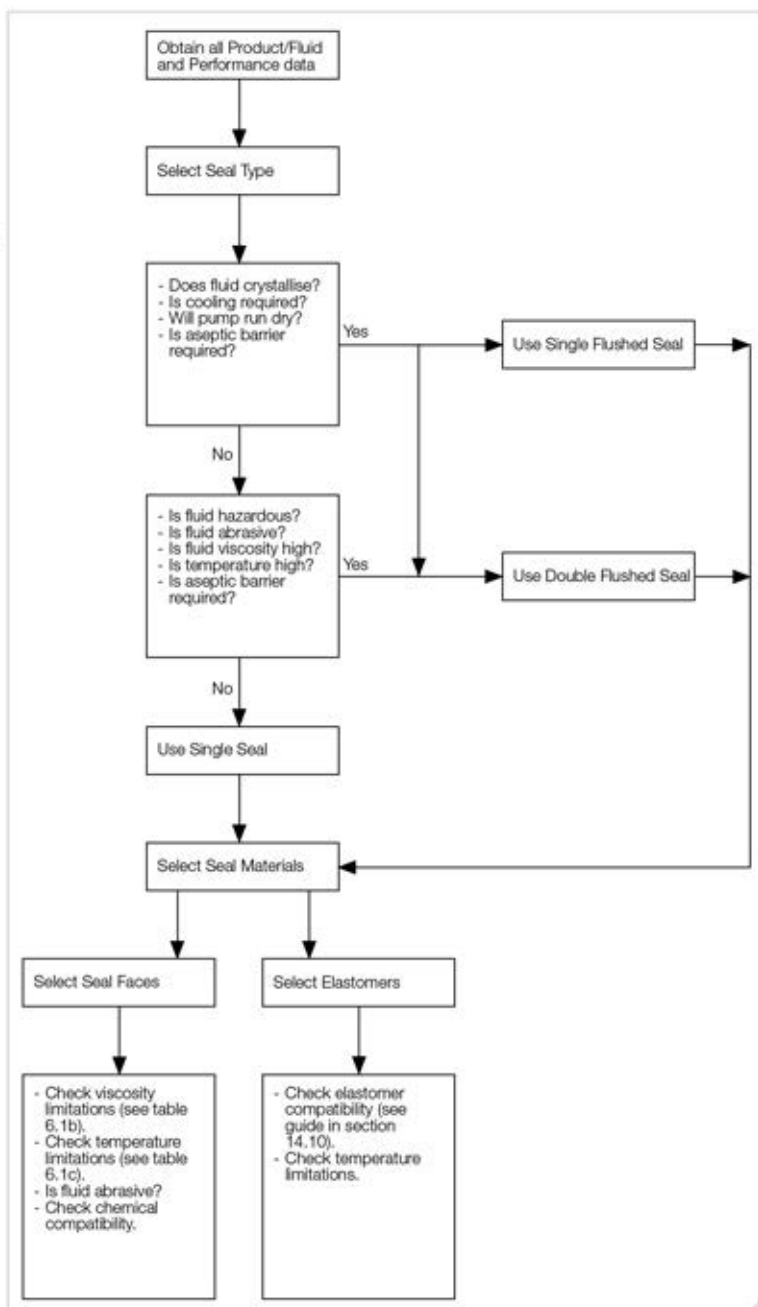

6.2 Mechanical Seal Types in Alfa Laval Pump Ranges

Seal Option Availability for Centrifugal and Liquid Ring Pumps

Pump Range	External Mounting			Internal Mounting	
	Single	Single Flushed	Double Flushed	Single	Single Flushed
LKH	✓	✓	✓		
LKH-Multistage				✓	✓
LKHP				✓	✓
LKHSP	✓	✓	✓		
LKHI				✓	✓
LKH-UltraPure	✓		✓		
MR-166S, -200S	✓				
MR-300				✓	

Table 6.2a

Seal Option Availability for Rotary Lobe Pumps

Table 6.2b

Mechanical Seal Type	Seal Name	Pump Range	
		SRU	SX
Single externally mounted	R90	✓	
	R00		✓
Single flushed externally mounted	R90	✓	
	R00		✓
Single flushed internally mounted	R90	✓	
	R00		✓
Double flushed	R90	✓	
	R00		✓

R90 Type Mechanical Seals

The basic working principles of the R90 type mechanical seals have previously been referred to in 6.1.

Hyclean Type Mechanical Seals

This seal arrangement is generally used for food and other hygienic applications. The design of this seal incorporates a self-cleaning feature.

Fig. 6.2a Hyclean single mechanical seal

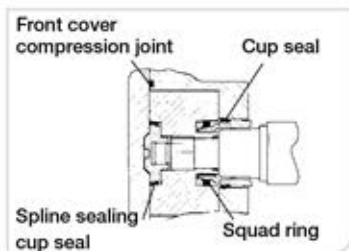
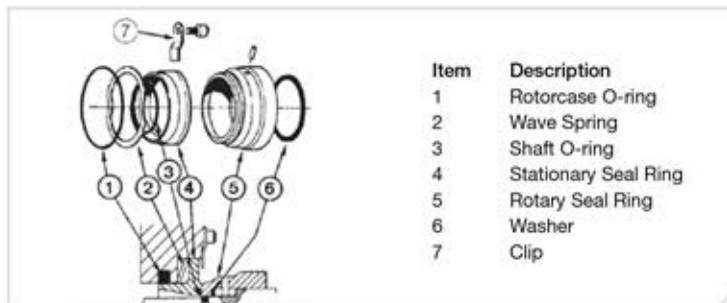
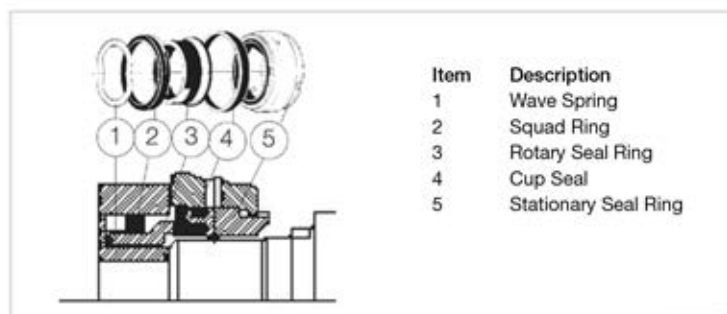

Fig. 6.2b SX pumphead sealing

Fig. 6.2c R00 single mechanical seal



R00 Type Mechanical Seals

The R00 type mechanical seals specifically designed for the SX rotary lobe pump range are fully front loading seals and fully interchangeable without the need for additional housings or pump component changes. Specialised seal setting of the mechanical seal is not required as the seal is dimensionally set on assembly. Seal faces positioned in the fluid area minimise shear forces. All seals have controlled compression joint elastomers at fluid/atmosphere interfaces.

6.3 Other Sealing Options (Rotary Lobe Pumps only)

This is a simple, low cost, and easy to maintain controlled leakage sealing arrangement. These are specified for many 'dirty' applications, but when possible, should always be avoided for sanitary duties, as they are less hygienic than mechanical seals.

Packed Gland

The grade of packing used depends on the product being handled and operating conditions. When packed glands are specified, using polyamide or PTFE packings will satisfy the majority of duties. Provided the liquid being sealed contains no abrasive particles or does not crystallise, gland packings will function satisfactorily on plain stainless steel shafts or renewable stainless steel shaft sleeves. In instances of moderately abrasive fluids, such as brine solutions being handled, the pumps should be fitted with hard coated shaft sleeves, which may be easily replaced when worn. Pumps provided with a packed gland seal are normally fitted with rubber slingers mounted between the gland followers and the gearcase front lip seals. The slingers will reduce the possibility of the product contacting the gearcase lip seals, thereby overcoming any undesirable operating conditions that could arise in this area. When correctly assembled and adjusted, a slight loss of product should occur so as to lubricate the packing and shaft or sleeve, if fitted.

Fig. 6.3a Packed gland

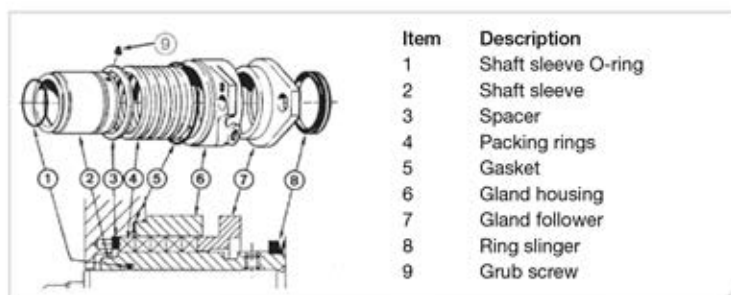

This seal arrangement is available on all SRU pump models.

Packed Gland with Lantern Ring

With fluids containing very abrasive particles or fluids that will coagulate, solidify or crystallise in contact with the atmosphere, a packed gland with lantern ring may be used. In such circumstances a compatible liquid is supplied to the chamber formed by the lantern ring at a pressure of at least 1 bar (14 psi) above the pump pressure. The function of this liquid is to prevent, or at least inhibit, the entry of abrasives into the very small clearances between the shaft and packing. In the case of liquids which coagulate, solidify or crystallise in contact with the atmosphere the flushing liquid acts as a dilutant and barrier in the gland area preventing the pumped fluid from coming in contact with the atmosphere.

A disadvantage with this seal arrangement is that the flushing liquid will pass into the product causing a relatively small degree of dilution/contamination, which cannot always be accepted.

In common with all packed gland assemblies slight leakage must occur but in this instance it will basically be a loss of flushing liquid as opposed to product being pumped.

Fig. 6.3b Packed gland with lantern ring

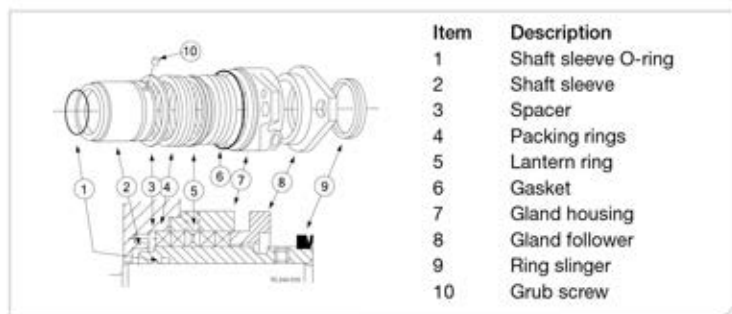

This seal arrangement is available on all SRU pump models.

